



Kerala Start-Up Mission (KSUM)

Formerly Technopark Technology Business Incubator (T-TBI)

G3B, Thejaswini, Technopark Campus
Thiruvananthapuram 695 581
Kerala State, India
Phone No: 08047180470

NOTICE INVITING QUOTATION

Date : 23 /02/2021

Sealed competitive quotations are invited from contractors for marking parking slots in ISC, Kalamassery. For more details please contact the office of The Manager, Kerala Startup Mission, Integrated Startup Complex, KTIZ, Kalamassery.

1	Quotation No:	KSUM/KTIZ/ISC/18/2020-21
2	Name of Project	Purchase of manual taps for replacing defective taps in washrooms of ISC
3	Scope of work	Supply of quality tested normal taps to the site on issue of purchase order
4	Probable amount of Contract	Rs.31983/- (Rupees Fifty Four Thousand Only)+ GST
5	Type of Quotation	Item rate Quotation
6	Basis of estimate	Market rate
7	Issue of Quotation Documents	Quotation documents can be downloaded free of cost from the e-GP website: https://startupmission.kerala.gov.in/tender

8	Quotation available for download	23rd February 2021 from 11:00 am
9	Quotation submission closing date & time	8th March 2021 at 6:00 pm
10	Quotation Opening Date	9th March 2021 at 12:00 pm
11	Pre bid meeting	01st March 2021 from 11:00 am
12	Clarifications if any	Visit the site before submitting the quotation
13	Commencement of work	15 days from the date of issue of purchase order / handing over of site whichever is later.
14	Completion period	30 days from the date of commencement of work
15	Escalation	Firm item rate without escalation
16	Bid Submission fee	Not applicable

17	Submission of Bids :Two Bid system	<p>Part I:Technical Bid (Submit the following documents)</p> <ol style="list-style-type: none"> 1.Quotation Documents (Notice Inviting Quotation, Terms & conditions) 2.Company registration details 3. Copy of GST registration 4.Documentary evidence of pre-qualification. 5.Technical specification document as per given in Annexure 1 <p>Part -II-Financial Bid</p> <ol style="list-style-type: none"> 1.As per the Format given in Annexure 2.
18	Earnest Money Deposit (EMD)	Not Applicable

19	Security Deposit / Performance Guarantee	Not applicable
20	Additional Security Deposit / Retention amount	Not applicable
21	Release of security deposit/Performance Guarantee /retention amount	Not applicable
22	Quotation Validity	6 months
24	Defects liability period	Not applicable
25	Minimum interim bills	No interim bills
28	Liquidated damages	Not applicable
29	Mobilization Advance	No Mobilization advance will be paid.
30	Address to which the bid is to be submitted (Hard Copy)	The Chief Executive Officer, Kerala Startup Mission,Integrated Startup Complex, KTIZ, Kalamassery.
31	Arbitration	Disputes, if any will be finalized under the jurisdiction of Court at Ernakulam.

Quotation should be submitted in sealed cover super-scribed "Quotation No. KSUM/KTIZ/ISC/18/2020-21". The quotation should be addressed to 'The Chief Executive Officer, Kerala Startup Mission, ISC, KTIZ, Kaalamassery'.

**Manager - Infrastructure
KSUM**

Terms and Conditions

1. Prices: Rate shall be inclusive of all taxes and duties except **GST**.

The **prices** shall be in **figures as well as in words**. In case of any discrepancy between the two, the amount written in words will be taken as correct. In case of discrepancy between unit rates and total price, the unit rates shall be taken as correct.

2. Validity

The **quotation should be valid for a minimum period of 6 months** from the date of opening of quotation.

3. Right of acceptance

KSUM reserves the right of rejecting any or all quotations wholly or partially without assigning any reasons whatsoever.

4. Commencement of work

4.1. 15 days from the date of issue of purchase order / handing over of site whichever is later.

5. Time of completion of supply/work

5.1. Time of completion will be 30 days from the date of commencement of work

6. Terms of payment

Payment would be made **within 30 working days after the submission, verification and acceptance of the bill**.

No mobilization advance will be made.

Mode of payment: Through cheque or online transaction only

7. Submission of quotation

7.1 The quotation shall be submitted in 2 covers - Technical and Financial covers. Technical specifications must be accepted as per annexure 1 and submit the financial bid in the prescribed format in the annexure 2.

8. Special condition

8.1 All the materials and tools required for the work shall be arranged by the contractor and the rate quoted must be inclusive of all these.

9. Acceptance of terms and conditions

9.1 The bidders must confirm their acceptance of the terms and conditions mentioned herein and in the enclosed documents. In case any clause is not acceptable to the manufacturer/supplier/contractor, it should be specifically brought out in the quotation failing which it shall be presumed that all clauses mentioned herein above are acceptable to the bidder.

10. Prequalification Criteria

10.1 The bidder should have undertaken and successfully completed at least one work of similar nature of contract value not less than Rs. 20 thousand within the last three (3) years, prior to the date of quotation notice for KSUM, Technopark, KINFRA or other reputed IT parks, PSUs or other reputed private organisations.

10.2 Any entity that has been barred by Central /State Governments in India, any entity controlled by them, from participating in any project, and the bar subsists as on the date of proposal, would not be eligible to submit a proposal.

10.3 Any Applicant should have, during the last three years, neither failed to perform on any agreement, as evidenced by imposition of a penalty by an arbitral or judicial authority or a judicial pronouncement or arbitration award against the Applicant, nor been expelled from any project or agreement nor have had any agreement terminated for breach by such applicant.

The attention of the bidder is drawn to the fact that the quotation documents are not transferable.

The documents to be submitted by Bidders for proving PQ criteria:

1. For PQ criteria no: 1 :- Completion certificate from the clients for satisfactory completion of the delivery / copy of bill submitted to the client after completion of delivery .
2. For PQ criteria 2&3 : Bidders should submit an undertaking in their own letter head for meeting the criteria.

Bidders are advised to ensure that all submittals called for are complete in themselves and shall note that non-submission of the documents as called for in the PQ criteria and also in other relevant pages elsewhere in this tender document may attract disqualification and no correspondence will be entertained with such bidders by KSUM. Quotation/bids are to be accompanied with all the documents under technical and financial bid

Manager - Infrastructure

KSUM

Annexure I

Technical Specification for the supply of manual taps for replacing defective taps in washrooms of ISC, Kalamassery

Sl No.	Items	Specifications
1	Manual tap	Pillar cock auto closing system with 65 mm extension body.

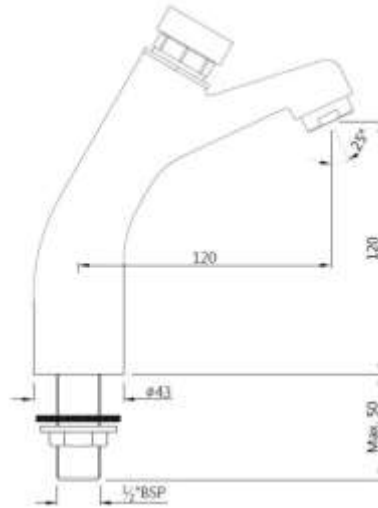

Name and address of the contractor/supplier :

Signature and seal of contractor/supplier :

Annexure 2

Financial Bid submission format

Sl N o	Item	Quantity	Unit	Rate	Amount
1	Supply of manual taps for replacing defective taps in washrooms of ISC	20	nos		
TOTAL					

***The rate quoted to be inclusive of all taxes and duties except GST**

Name and address of the contractor/supplier :

Signature and seal of contractor/supplier :

Annexure III

No.....

Date:.....

Undertaking

I/We hereby affirm that any entity that has been barred by Central /State Governments in India, any entity controlled by them, from participating in any project, and the bar subsists as on the date of proposal, would not be eligible to submit a proposal.

Also affirm that, during the last three years, we have neither failed to perform on any agreement, as evidenced by imposition of a penalty by an arbitral or judicial authority or a judicial pronouncement or arbitration award against the Applicant, nor been expelled from any project or agreement nor have had any agreement terminated.

Name and address of the contractor/supplier:.....

Seal and signature of the contractor/supplier:.....